

AA **ANTUNES** CONTROLS

DIVISION OF A.J. ANTUNES & CO.

TEMPERATURE CONTROLLERS 1/8 DIN WITH DIGITAL DISPLAY MODEL-TCE

INSTALLATION INFORMATION

SPECIFICATIONS

SENSOR: Thermocouple (Type J or K)

ACCURACY: 1% Full Scale \pm 1 LSD

AMBIENT OPERATING

TEMPERATURE: -30°F to 140°F
(-35°C to 60°C)

AMBIENT STORAGE

TEMPERATURE: -40°F to 180°F
(-40°C to 82°C)

POWER: 12 Vac/DC, 24 Vac, 115 Vac,
230 Vac, 50/60 Hz

PACKAGE: 1/8 Din Panel Mount
Anodized Aluminum Case

OUTPUT: 3A Relay, Standard
(Resistive Load) or 12-16 VDC
@ 30 mA

CONTROL: On/Off.

DISPLAY: 3 Digit LED (0.56" High)

CONNECTIONS: Screw Terminal

HYSTERESIS: Typically 1-2° unless
ordered otherwise

SET POINT ADJUSTMENT:

External Knob or Recessed Screw
Driver Adjustment

TEMPERATURE RANGE: 50° - 940°F
(10° - 530°C)



THESE TEMPERATURE CONTROLLERS ARE COMPACT AND EASILY INSTALLED. PLEASE READ THIS FOLDER CAREFULLY TO ASSURE CORRECT INSTALLATION. THIS EQUIPMENT MUST BE INSTALLED BY LICENSED ELECTRICIAN. PRIOR TO BEING PUT INTO OPERATION, CHECK ALL WIRING AND FUNCTION OF UNIT.

FIGURE 1 DIMENSIONS IN INCHES

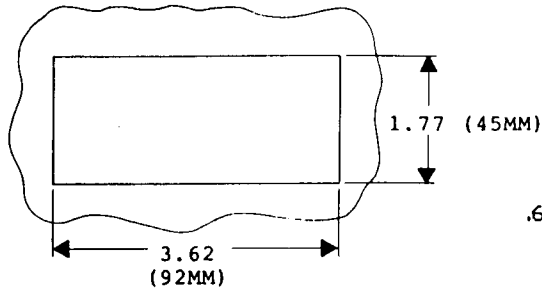
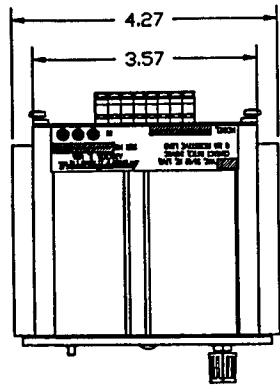

**FIGURE 2
PANEL CUT-OUT**

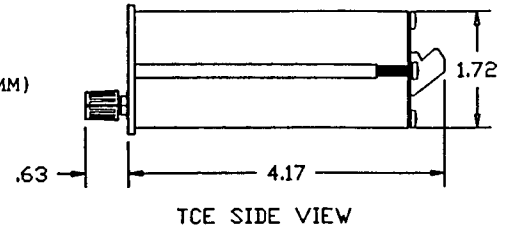

TCE SIDE VIEW

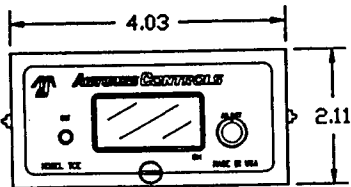
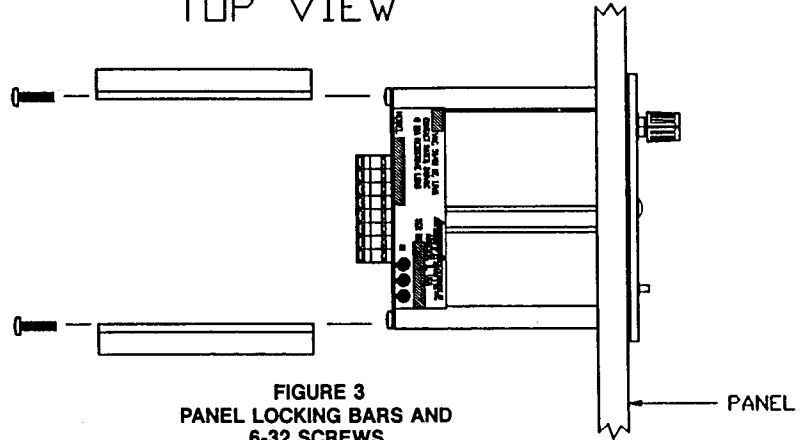

Figure 1 above shows the dimensions of the TCE controller. Figure 2 shows the panel cut-out size required to mount the unit. Insert the unit into the panel from the front. Secure in place to the panel with the 2 locking bars and screws provided with the unit (see Figure 3)

TOP VIEW



**FIGURE 3
PANEL LOCKING BARS AND
6-32 SCREWS**

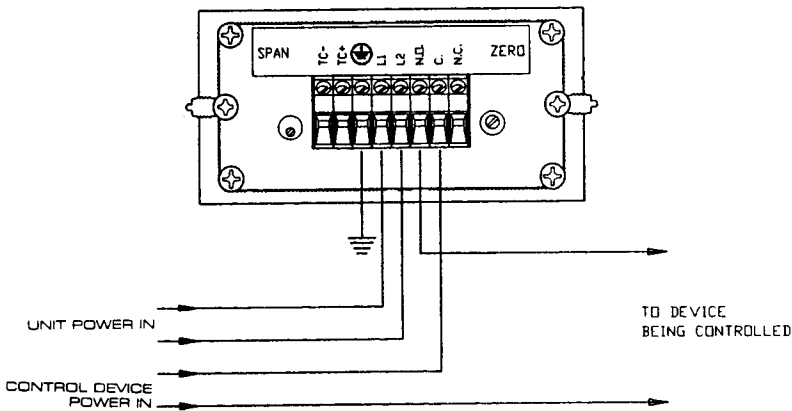

FIGURE 4

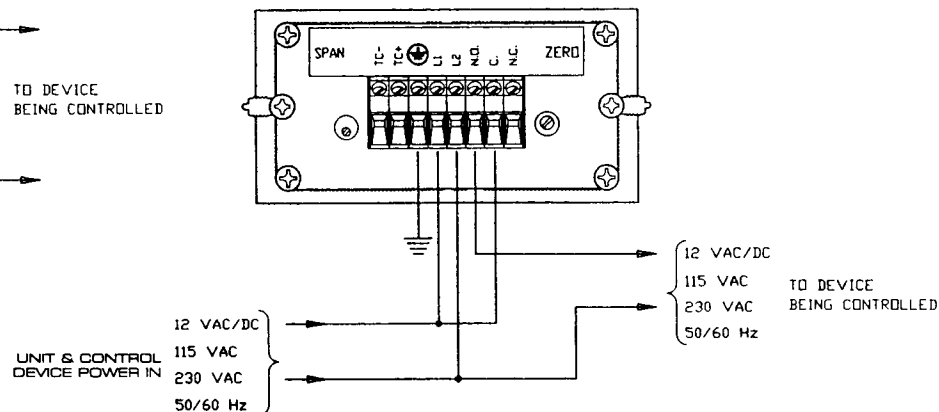

FIGURE 5

Figures 4 and 5 illustrate how to wire the relays for the different power requirements. The relay must have an external power source for you to be able to control your device.

WIRING DIAGRAM

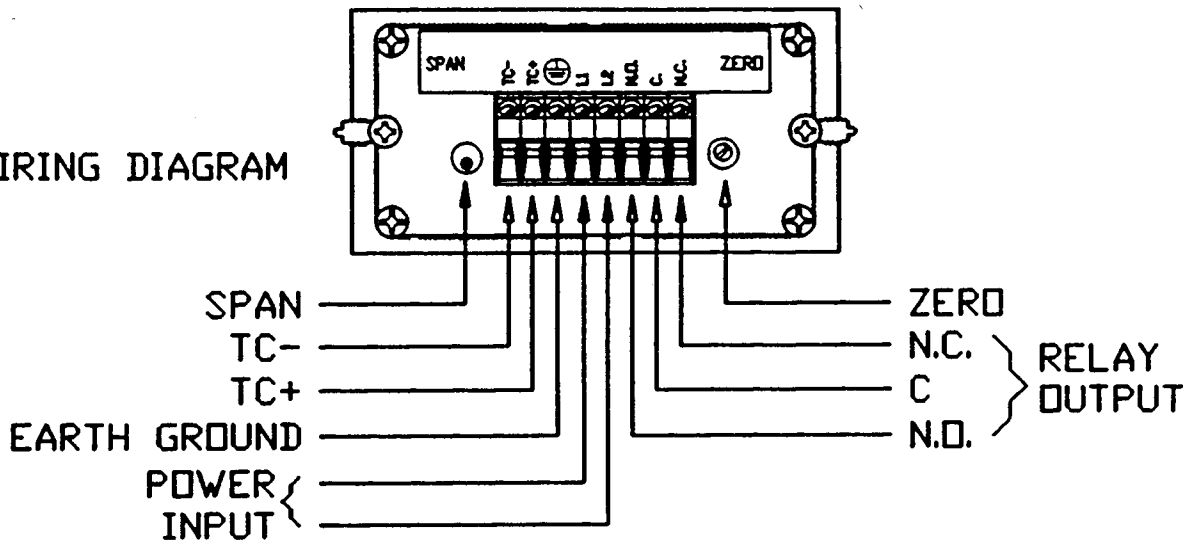

FIGURE 6
WIRING INFORMATION

Figure 6 shows connections for a type J or K thermocouple wire via terminals. For long thermocouple runs the proper thermocouple extension wire must be used, and the proper polarity must be maintained. If these precautions are not observed, the unit may not meet specifications. Power and thermocouple wire should not be placed in the same conduit or wiring trough. However, wires from several thermocouples may be in the same conduit or wiring trough. If shielded thermocouples are used, the shields should be

insulated electrically from the thermocouple wires and terminated to earth ground.

The unit will read "EEE" for over range conditions, and "- - -" for under range conditions.

If field calibration is required, a two point calibration with a millivolt generator can be used. Allow 30 minutes for the unit to stabilize before calibrating. Calibrate the low reading by adjusting the zero pot. Enter the second calibration higher than the first point and adjust the span. Recall these two points if needed.

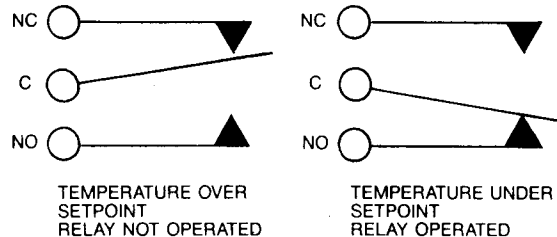
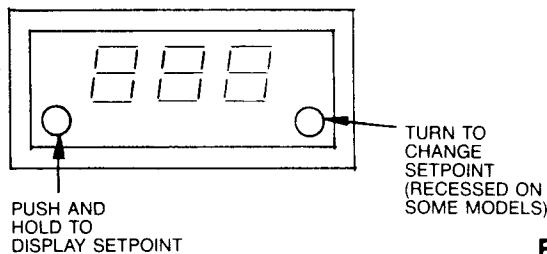

FIGURE 7
SET POINT CALIBRATION AND OUTPUT STATES

When the button on the lower left of the unit is pushed in and held the set point is displayed. As long as the button is held in the set point is displayed. When the button is out the temperature at the thermocouple is displayed.

The knob on the lower right is used to change the set point. Turn the knob clockwise to increase the set point. Turn the knob counter clockwise to decrease the set point.

CAUTION: The set point can be changed without displaying the set point. Do not turn the set point

knob unless you want the set point changed.

Figure 7 shows the output states of the controller internal relay when the temperature as seen by the thermocouple is above or below the set point. When the relay is energized the decimal point following the least significant digit (extreme right) will be illuminated. Make connections accordingly, observing the power rating of the contacts. If the thermocouple "opens" the internal relay will go to its "not operated" state.

SOLID STATE RELAY OUTPUT

When the temperature seen by the thermocouple is above the set point, there will not be any voltage between - and + terminals (pin 8 & 6). If the temperature seen by the thermocouple is below

the setpoint, there will be 12-16 VDC output. This output is capable of providing 30 mA. If an "open" thermocouple condition occurs, the voltages between pins 8 & 6 will be zero.

LIMITATION OF LIABILITY. It is understood and agreed that seller's liability whether in contract, in tort, under any warranty, in negligence or otherwise shall not exceed the return of the amount of the purchase price paid by purchaser and under no circumstances shall seller be liable for special, indirect or consequential damages.

The price stated for the equipment is a consideration in limiting seller's liability. No action, regardless of form, arising out of the transactions may be brought by purchaser more than one year after the cause of action has accrued.

WARRANTY

1. Antunes Controls products are guaranteed to be free from mechanical and electrical defects for a period of one year from date of shipment under normal use and service provided installation is made in accordance with manufacturers recommendations.
2. Parts deemed defective shall be repaired or replaced at manufacturers option and at manufacturers expense but shall not include foreign or federal excise taxes, state or municipal sale or use taxes, all such taxes not limited to the foregoing being responsibility of the purchaser.
3. No charge for travel and/or mileage will be allowed to purchaser.
4. Antunes Controls reserves the right to make changes in design or make any improvements on any products. The right is always reserved to modify our equipment because of new technology, underwriter's requirements and/or government regulations.
5. The following are not covered under warranty:
 - a. Failure from neglect, abuse, careless handling and mis-application of unit.
 - b. Failure to observe guidelines for installation or improper voltage hook-up.
 - c. Failure caused by improper maintenance. (See maintenance guidelines found in operation instructions.)
 - d. Unless specifically allowed by Antunes Controls, no other charges may be included under warranty.

 **ANTUNES** **CONTROLS**

DIVISION OF A.J. ANTUNES & CO.

180 KEHOE BLVD., P.O. BOX 87700, CAROL STREAM, IL 60188 • PHONE 630-784-1000 • 1-800-253-2991 • FAX 630-784-1651
www.antunescontrols.com